

Bicycles carrier

Installation and usage instructions

EN

Fahrradträger

Montage- und Gebrauchsanleitung

DE

Porte-vélos

Instructions de montage et mode d'emploi

FR

Portabicicletas

Instrucciones de montaje y uso

ES

Portabici

Istruzioni di montaggio e d'uso

IT

Fietsendrager

Montage- en gebruiksinstructies

NL

Cykelhållare

Monterings- och bruksanvisning

SV

Cykelholder

Monterings- og brugsvejledning

DA

Sykelstativ

Monterings- og bruksinstruksjoner

NO

Pyöräteline

Asennus- ja käyttöohjeet

FI

Porta-bicicletas

Instruções de montagem e de uso

PT

CARRY-BIKE

CARAVAN ACTIVE E-BIKE

02094-06A



CARAVAN

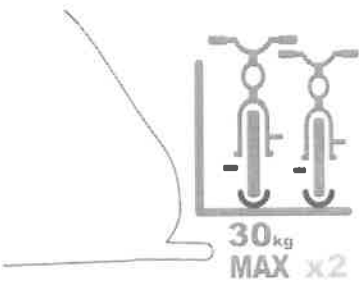
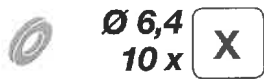
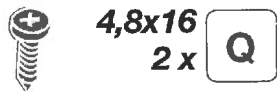
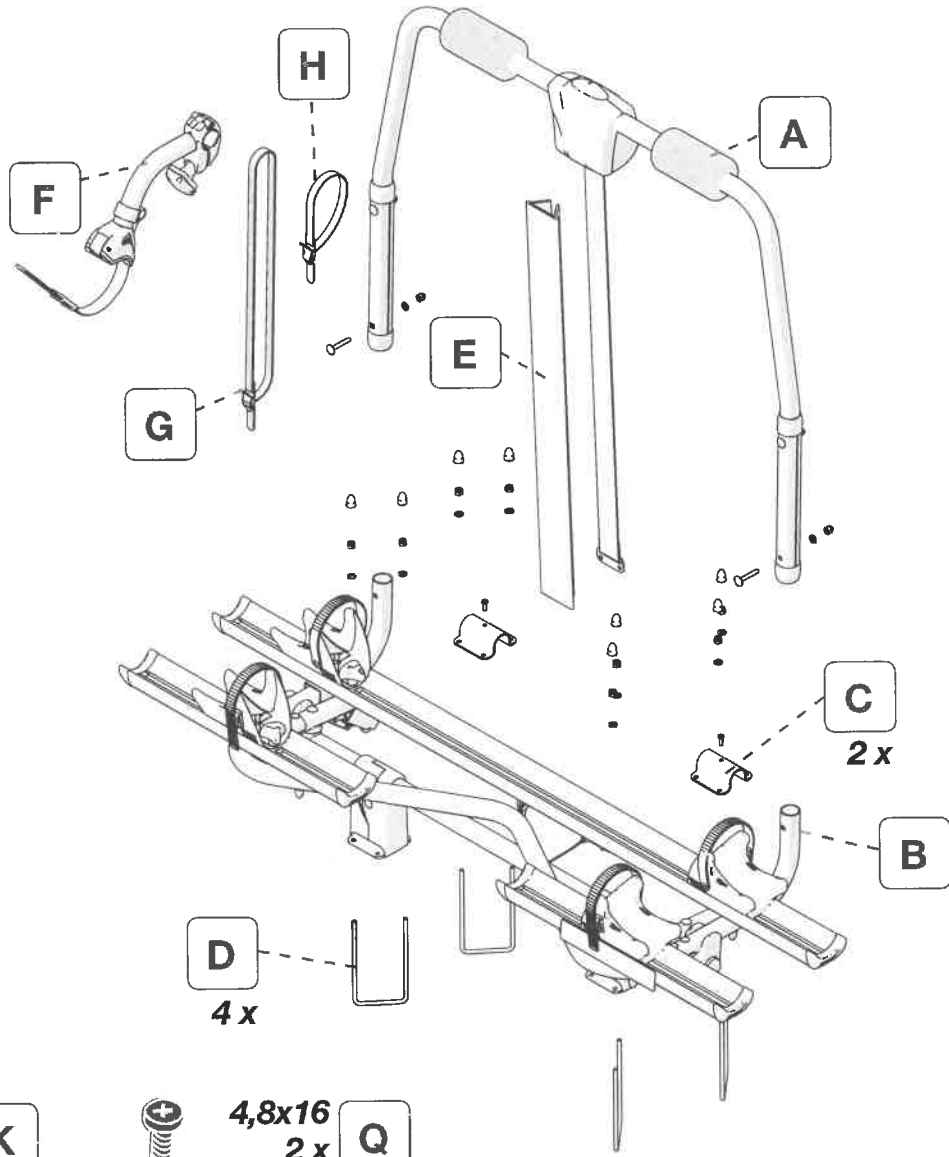

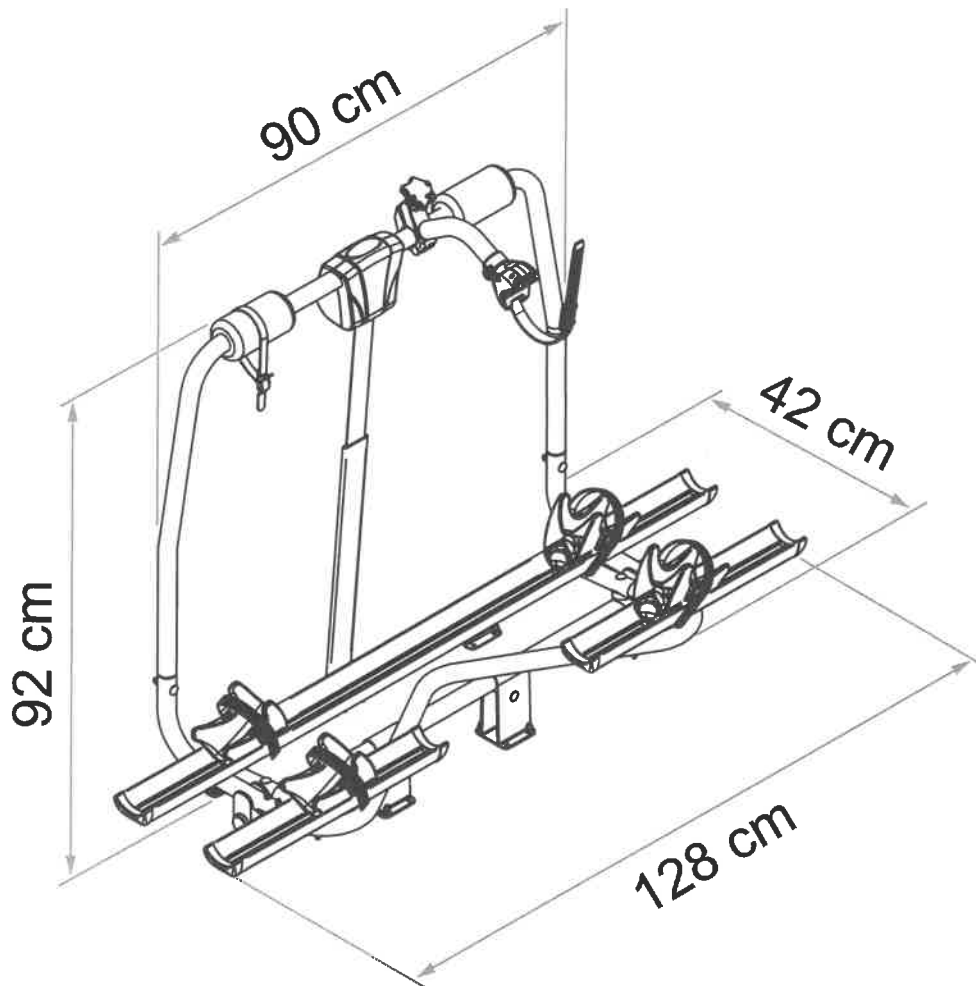

Package contents / Verpackungsinhalt / Contenu de l'emballage / Contenido del embalaje / Contenuto dell'imballo / Inhoud van de verpakking / Förpackningens innehåll / Pakkens indhold / Inholdet i pakningen / Pakkauksen sisältö / Conteúdo da embalagem	p. 2
Installation instructions / Montageanleitung / Instructions de montage / Instrucciones de montaje / Istruzioni di montaggio / Montage-instructies / Monteringsanvisningar / Monteringsvejledning / Monteringsinstruksjoner / Asennusohjeet / Instruções de montagem	p. 5
Instructions for use / Gebrauchsanleitung / Instructions d'installation / Instrucciones de uso / Istruzioni di utilizzo / Gebruiksaanstructies / Bruksanvisning / Brugsvejledning / Bruksinstruksjoner / Käyttöohjeet / Instruções de utilização	p. 8
Safety instructions / Sicherheitshinweise / Consignes de sécurité / Instrucciones de seguridad / Avvertenze di sicurezza / Veiligheidswaarschuwingen / Säkerhetsföreskrifter / Sikkerhedsforan- staltninger / Sikkerhedsadvarsler / Turvallisuusvaroitukset / Advertências de segurança	p. 11
Accessories / Zubehör / En option / Accesorios / Accessori / Benodigdheden / Tillbehör / Tilbehør / Tilbehør / Lisävarusteet / Acessórios	p. 14
Warranty / Garantie / Garantie / Garantía / Garanzia / Garantie / Garanti / Garanti / Garanti / Takuu / Garantia	p. 15



EN

Check that nothing has been damaged or deformed during transport. In case of damage please contact the dealer.
We recommend that the installation is carried out by qualified personnel and in compliance with current local regulations.

DE

Bitte kontrollieren Sie, dass alle Einzelteile einwandfrei sind und nicht während dem Transport beschädigt wurden. Wenden Sie sich in diesem Falle an Ihren Händler.
Wir empfehlen die Anbringung durch Fachpersonal in Übereinstimmung mit den geltenden lokalen Vorschriften vornehmen zu lassen.

FR

Contrôler le contenu du colis et vérifier qu'aucune pièce n'ait été cassée ou déformée durant le transport. Sinon, contacter le revendeur.
L'installation doit être réalisée par des personnes dûment qualifiées et conformément aux normes en vigueur dans le pays d'installation.

ES

Controlar que ningún detalle se haya roto o deformado durante el transporte. En este caso contactar al revendedor.
Recomendamos que la instalación se realice por personal cualificado en conformidad con las regulaciones locales.

IT

Controllare che nessun particolare sia rotto o deformato a causa di errori di trasporto.
In questo caso contattare il rivenditore.
Consigliamo di far eseguire l'installazione da parte di personale qualificato ed in conformità alle vigenti normative locali.

NL

Controleer of er geen onderdelen zijn gebroken of vervormd als gevolg van het transport.
Neem in dat geval contact op met uw dealer.
Wij raden u aan de montage te laten uitvoeren door gekwalificeerd personeel en in overeenstemming met de geldende plaatselijke voorschriften.

SV

Kontrollera att inga delar har skadats eller deformerats under transporten. Kontakta i detta fall återförsäljaren.
Vi rekommenderar att kvalificerad personal utför installationen i överensstämmelse med gällande lokala standarder.

DA

Kontrollér, at ingen del er ødelagt eller deformeret grundet fejl under transport. I dette tilfælde kontaktes forhandleren.
Vi anbefaler, at monteringen udføres af kvalificeret personale og i overensstemmelse med gældende lokale regler.

NO

Kontroller at ingen deler er ødelagt eller deformert som følge av feil under transporten.
Ta i så fall kontakt med forhandleren.
Vi anbefaler at installasjonen gjennomføres av kvalifisert personale og i samsvar med gjeldende lokale regler.

FI

Tarkasta, että mikään osa ei ole kuljetusvirheiden vuoksi rikkoutunut tai vääntynyt.
Siinä tapauksessa ota yhteys jälleenmyyjään.
Anna asennus tehtäväksi ammattitaitoiselle henkilöstölle ja siinä on noudatettava paikallisia voimassa olevia määräyksiä.

PT

Controlar que nenhuma peça tenha ficado partida ou deformada devido a erros de transporte.
Neste caso contactar o revendedor.
Aconselhamos a fazer executar a instalação por pessoal qualificado e em conformidade com as normas locais em vigor.

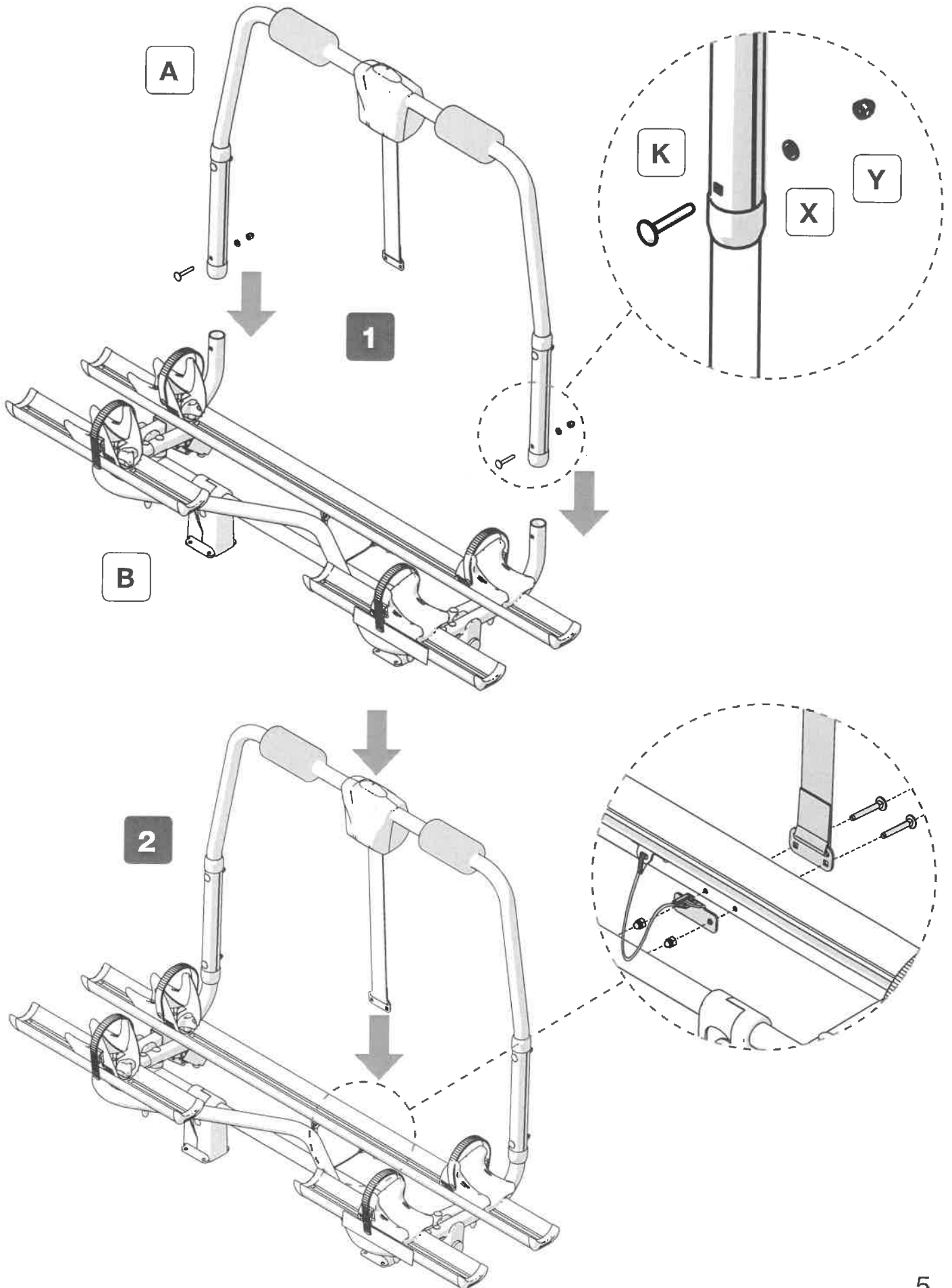



3

C
2x

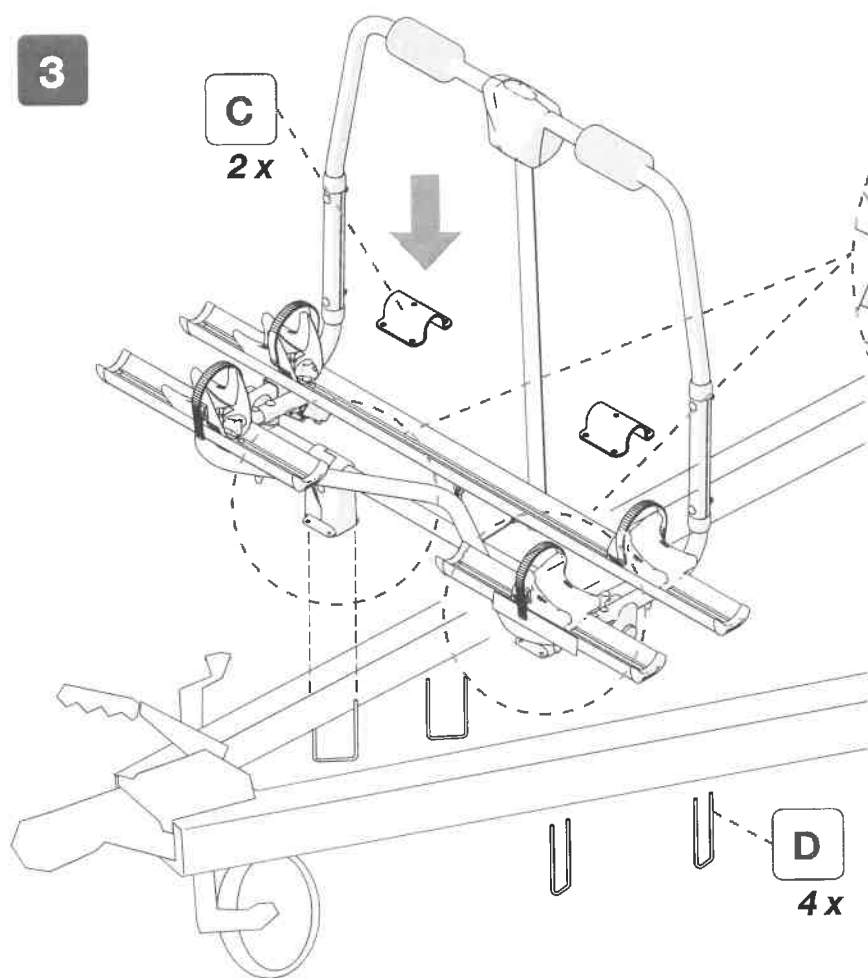

D
4x



W

Z

X

8x

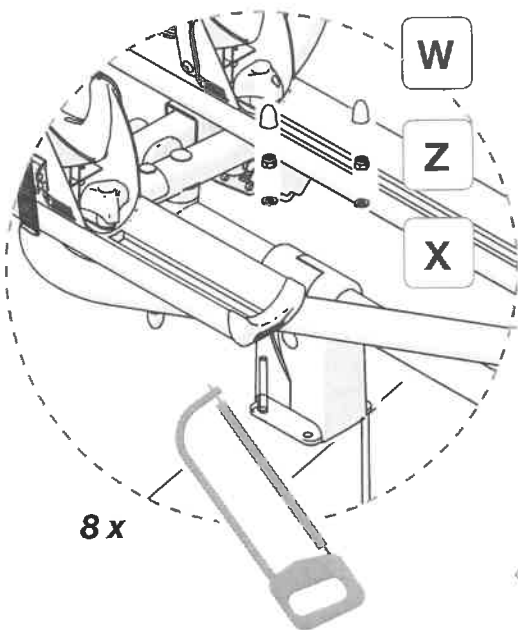

4

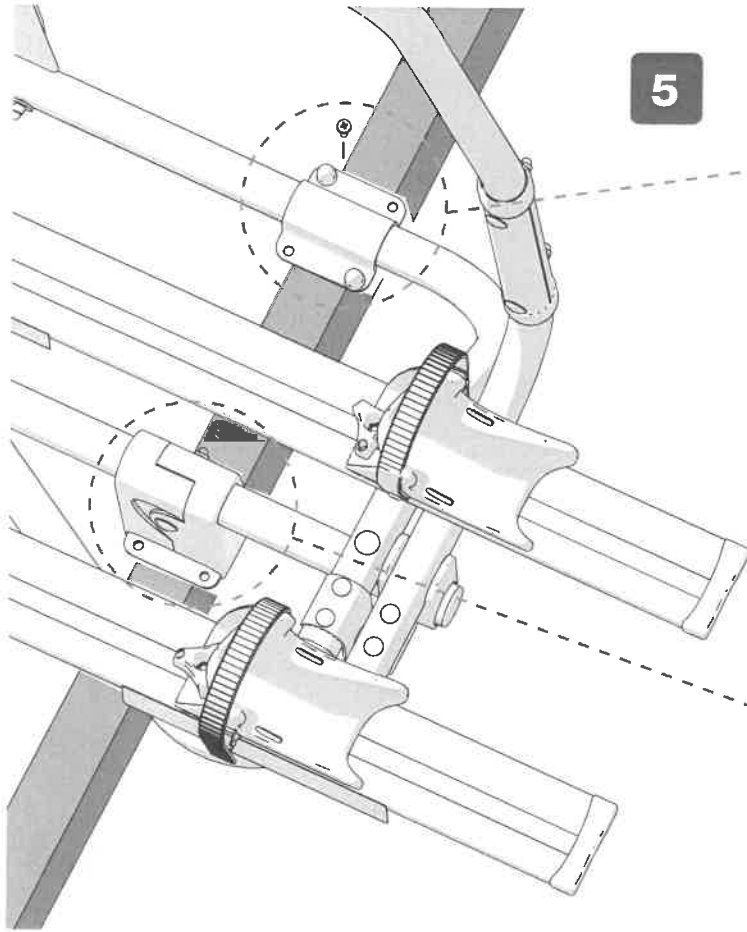

5

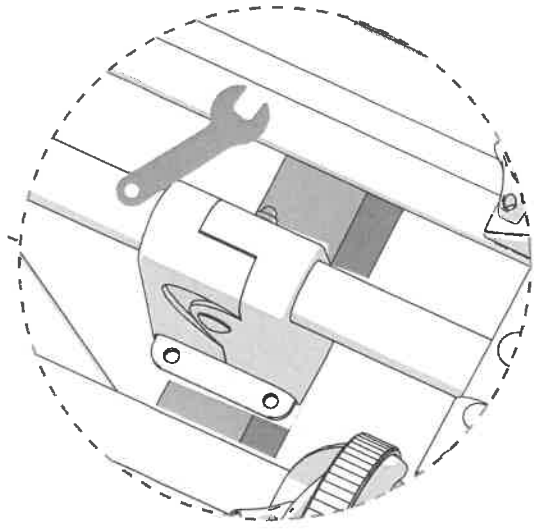
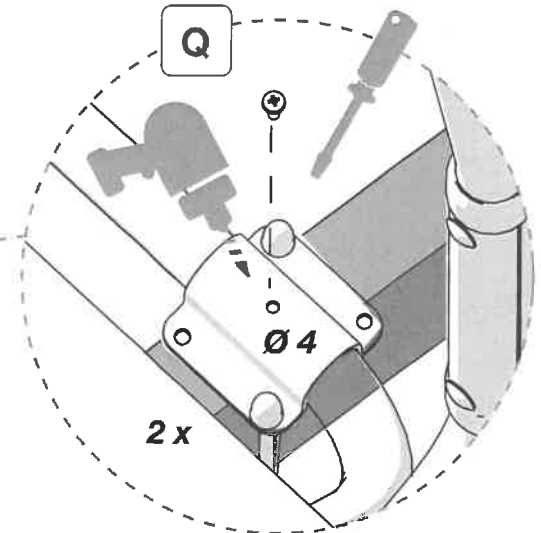

6

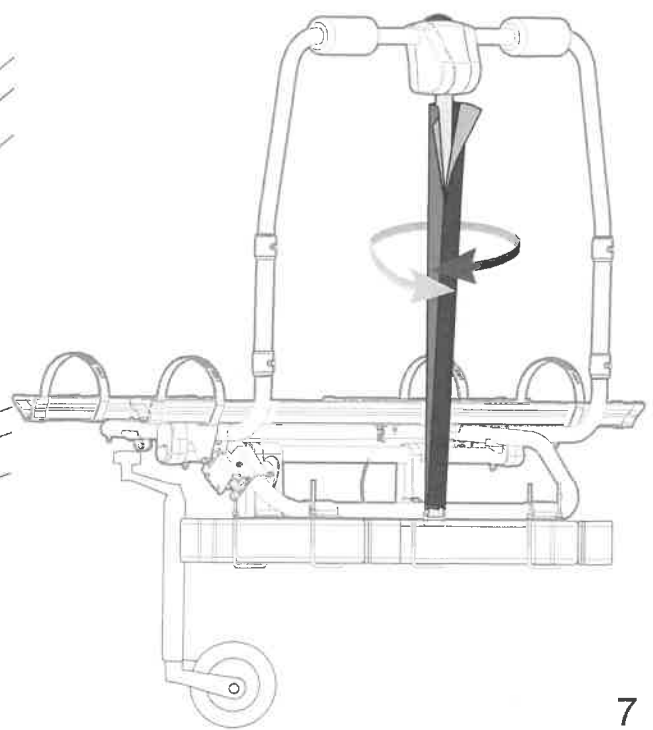
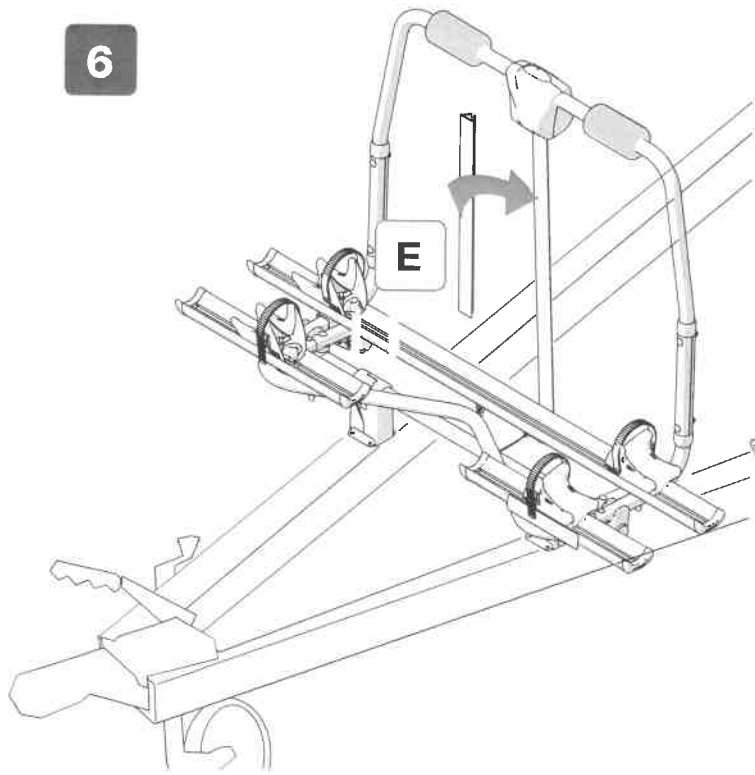

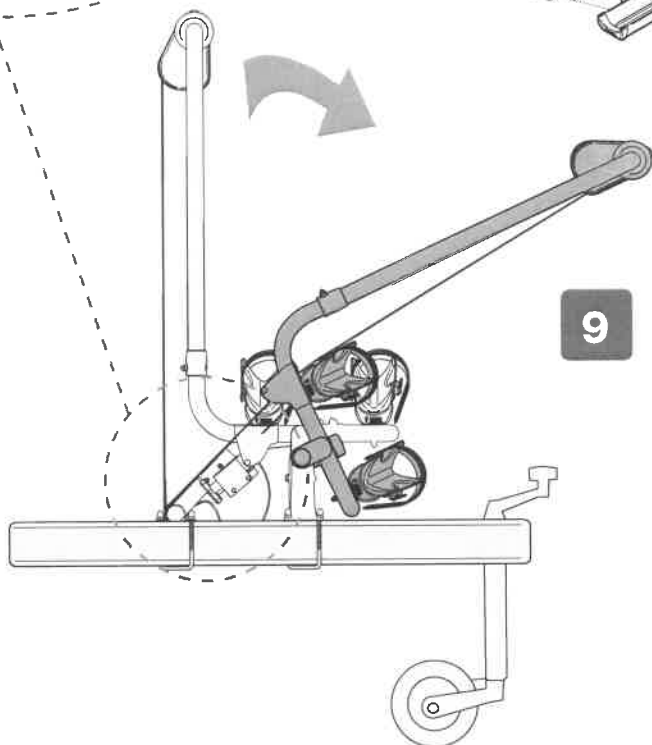
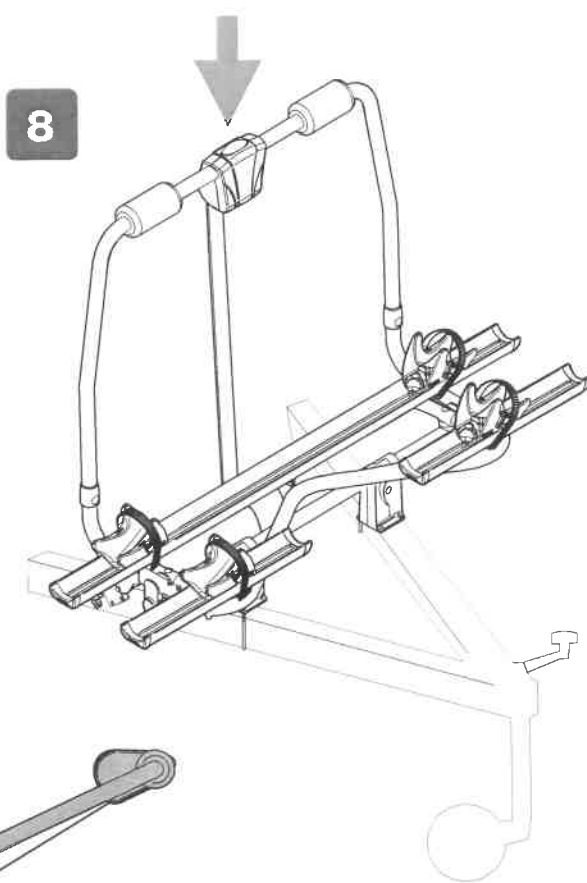
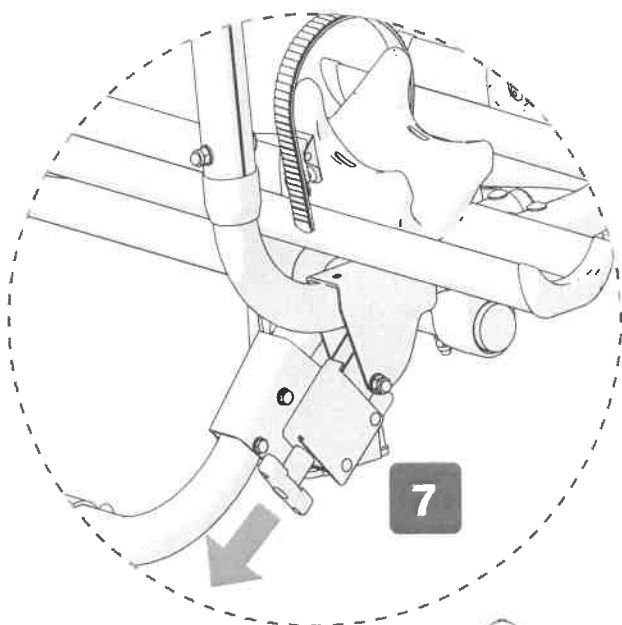
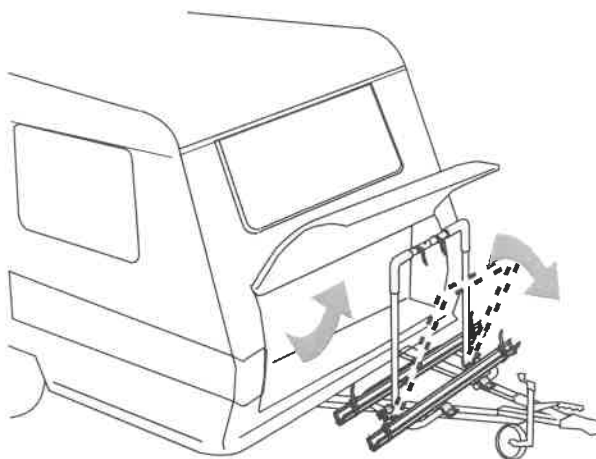
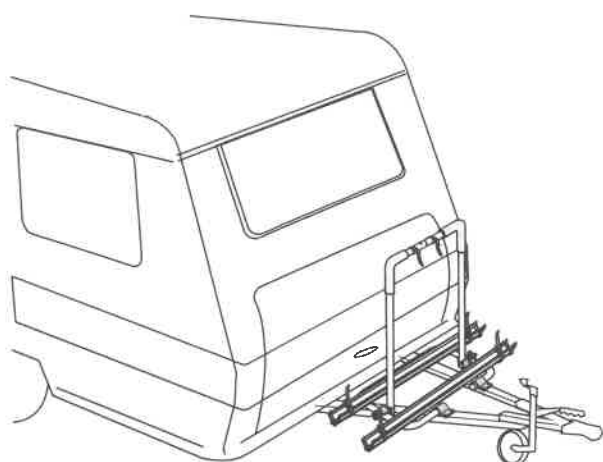

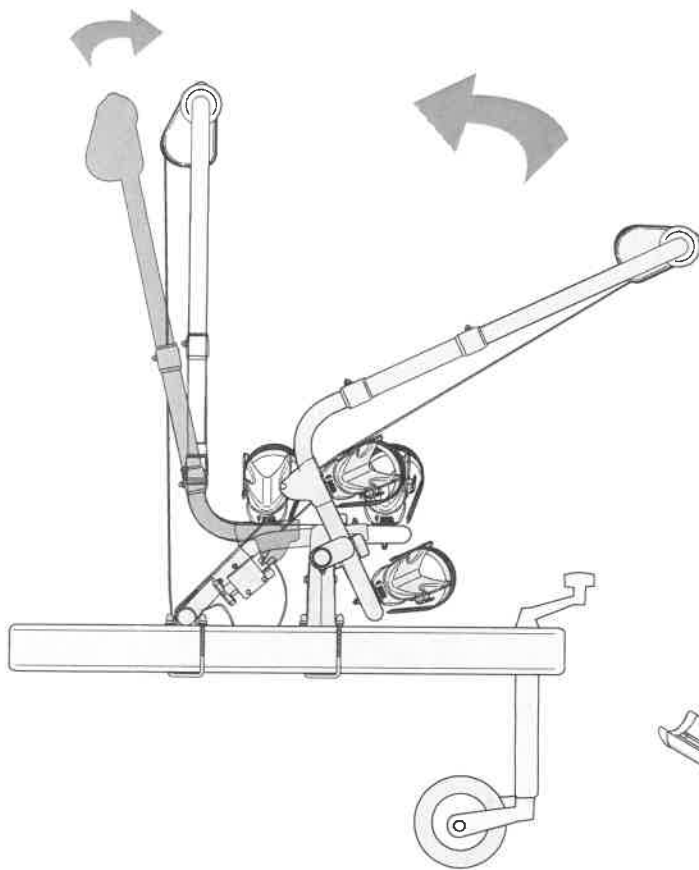

10

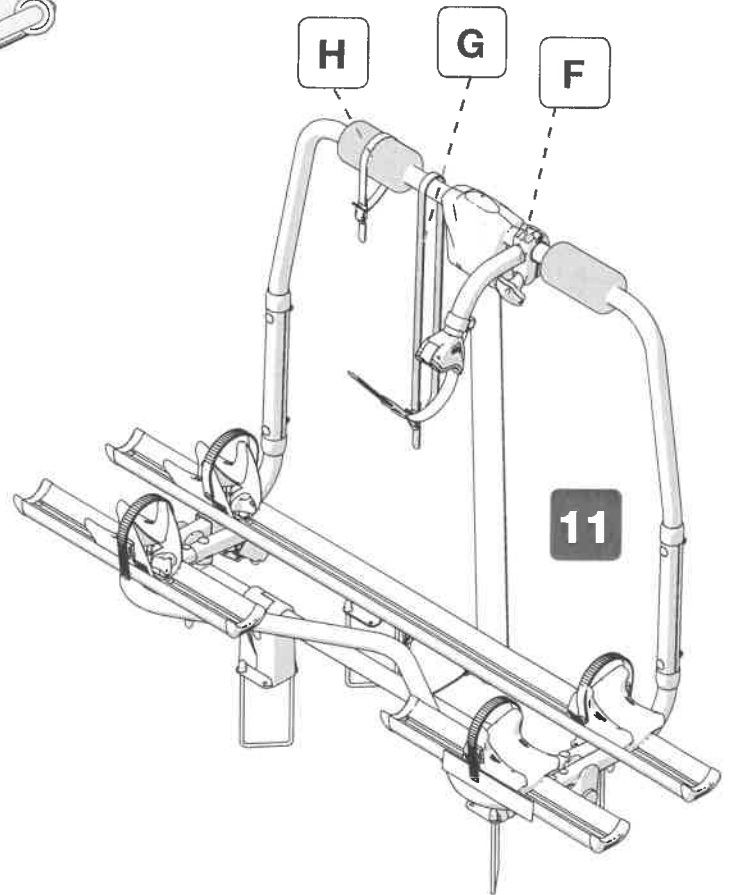

11

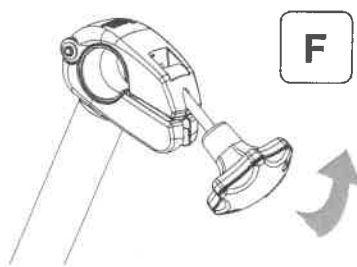

F

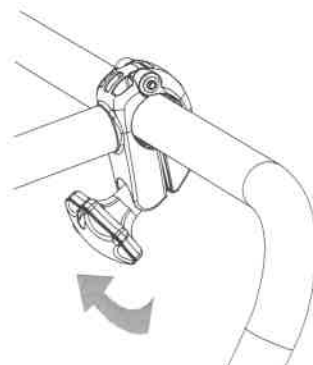
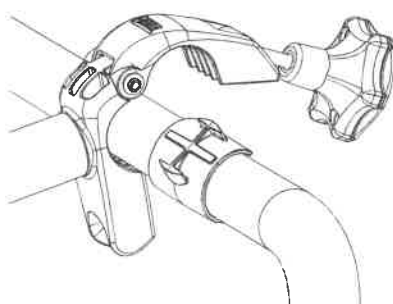
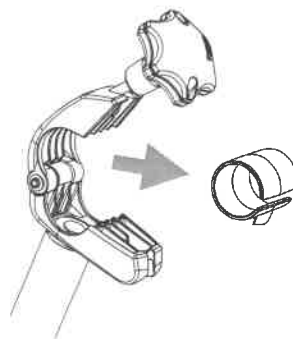

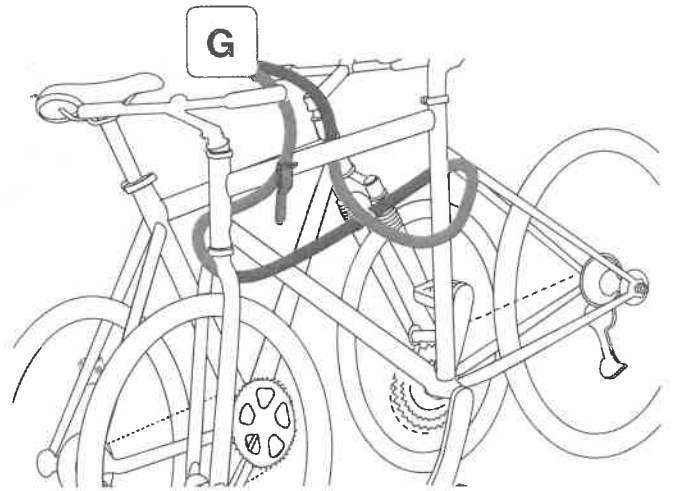
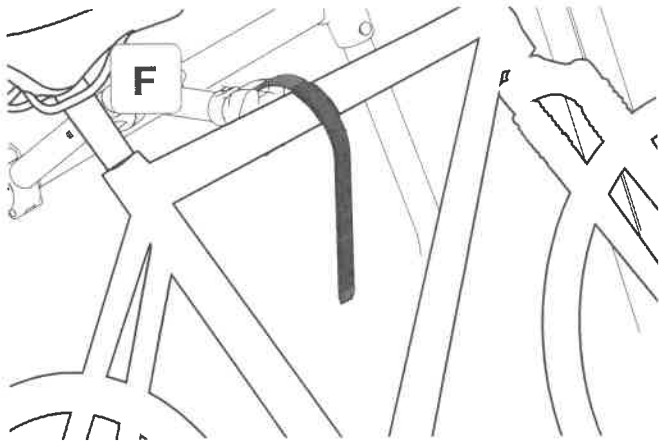
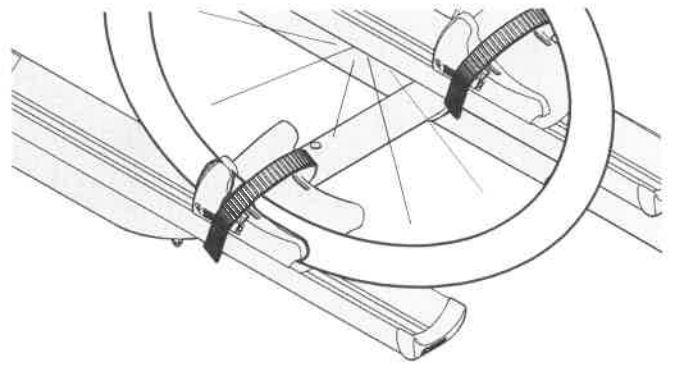
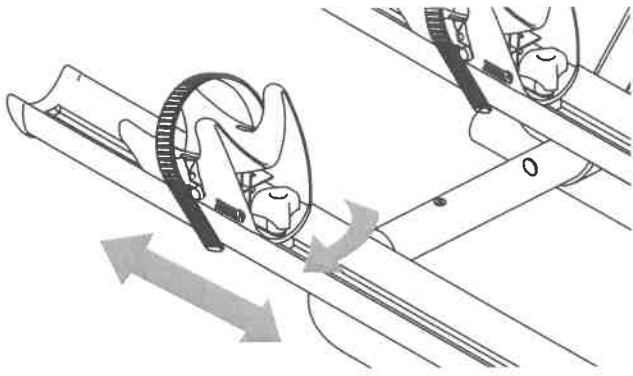

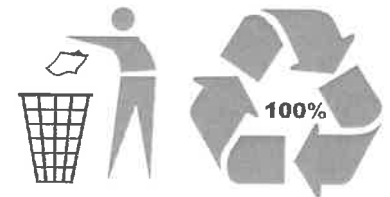
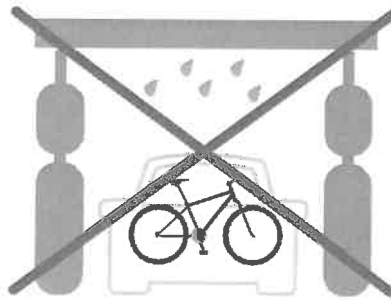
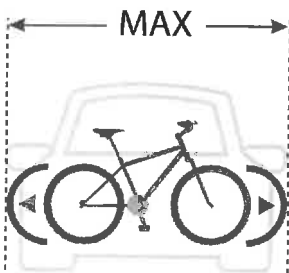
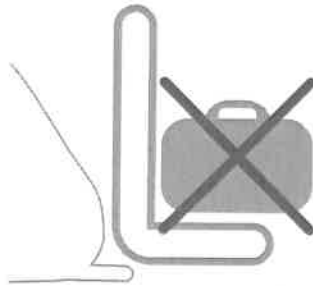
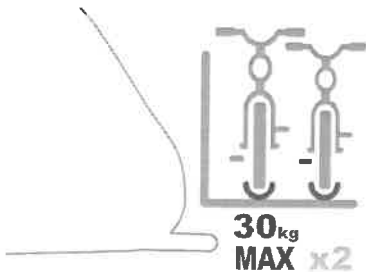

FP: 999999 M00
Carry-Bike®
 S/N: N 2000001

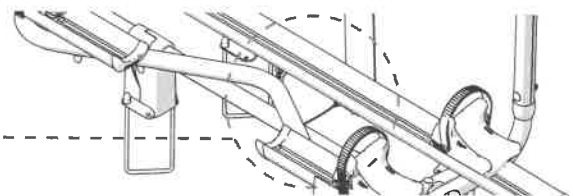

- EN** In case of problems please contact your local dealer indicating the data on the nameplate. Consult our website for spare parts drawing.
- DE** Bei Problemen bitte den Händler kontaktieren und die auf dem Etikett aufgeführten Daten mitteilen. Auf der Homepage finden Sie die Explosionszeichnung
- FR** En cas de problème, contacter le revendeur et lui communiquer les informations reportées sur la plaquette. Consulter le site Internet pour une vue éclatée des pièces de rechange.
- ES** En caso de cualquier problema, ponerse en contacto con su distribuidor local facilitando los datos sobre la placa. Consultar el sitio web para el despiece de los repuestos.
- IT** In caso di problemi contattare il rivenditore di zona, comunicando i dati riportati sulla targhetta. Consultare il sito web per l'esplosione ricambi.
- NL** Raadpleeg uw lokale dealer in geval van problemen onder vermelding van de gegevens op het typeplaatje. Raadpleeg de website voor de detailtekening met onderdelen.
- SV** Vid problem, kontakta en lokal återförsäljare och uppge uppgifterna som står på typskylten. Gå till webbplatsen för en sprängskiss över reservdelar.
- DA** Kontakt din lokale forhandler i tilfælde af problemer, og angiv oplysningerne på skiltet. Rådfør med webstedet for listen over reservedele.
- NO** Ved problemer ta kontakt med den lokale forhandleren, og oppgi informasjonen på merkeplaten. Se nettsidene for detaljert tegning av reservedelene.
- FI** Mikäli ilmenee ongelmia, ota yhteys alueen jälleenmyyjään ja ilmoita kilvessä olevat tiedot. Varaosien irto-osakuvat löytyvät nettisivuilta.
- PT** Em caso de problemas contactar o revendedor de zona, comunicando os dados gravados na chapa. Consultar o sítio web para a vista explosiva das peças sobresselentes.





EN

Fiamma declines all liability for any personal injury or damage due to mounting or inability to use the product. It is suggested to keep the bike carrier instructions inside the vehicle.

Product installation is to proceed according to the mounting instructions; the product may not be modified or altered in any way.

Take into account the presence of the Carry-Bike, paying attention during driving and especially during reversing manoeuvres, particularly if you have parking assist system.

In case of use of the bike carrier with tow make sure that the tow hook is always accessible and the corner mobility of the tow is guaranteed (volume measuring din 74058).

Check periodically the bicycle rack to make sure it is firmly attached, especially during the first kilometers of after long trips to avoid damages of the Carry-Bike/vehicle. Make sure the belts are not loose and that the holding brackets have not shifted.

Replace worn components immediately.

It is advisable to remove the batteries from bicycles, before loading them on the carry-bike while traveling.

DE

Fiamma lehnt jegliche Haftung für Personen- oder Sachschäden aufgrund unsachgemäßer Montage oder unsachgemäßem Gebrauch des Produktes ab; es wird empfohlen, die Anweisungen des Fahrradträgers im Fahrzeug aufzubewahren.

Die Montage muss gemäß der Montageanleitung erfolgen, das Produkt darf in keinster Weise abgeändert werden.

Beim Mitführen des Carry-Bike auf die dadurch abgeänderte Manövrierfähigkeit achten, vor allem beim rückwärtsfahren mit Fahrzeugen, welche mit einem Parksensoren ausgestattet sind.

Beim Mitführen eines Anhängers darauf achten, dass die Anhängerkupplung jederzeit zugänglich und die Winkelbeweglichkeit gemäß der DIN74058 gewährleistet ist.

Prüfen Sie regelmäßig die Befestigung des Fahrradträgers, insbesondere nach einer ersten gewissen Fahrt und jeweils vor und nach einer längeren Fahrt. Die Schutzgummis und Riemen regelmäßig überprüfen und falls porös oder abgenutzt dringend ersetzen.

Wir empfehlen die Batterie des Fahrrades vor dem Beladen auf den Träger abzunehmen.

FR

Fiamma décline toute responsabilité pour d'éventuelles lésions personnelles ou dommages matériels dus à un montage ou à une utilisation erronée du produit. Conserver soigneusement la notice du porte-vélos à l'intérieur du véhicule.

Le montage de l'article doit être effectué en respectant les instructions de la notice d'installation. Aucune modification ne doit être apportée au produit.

Conduire avec un porte-vélos demande de savoir adapter son style de conduite en faisant tout particulièrement attention aux manœuvres de marche arrière, spécialement si le véhicule est équipé de dispositif d'aide au stationnement.

En cas d'utilisation avec une remorque, vérifier que le crochet d'attelage soit accessible et que le mouvement angulaire de la remorque soit garanti (mesure du volume DIN 74058).

Contrôler régulièrement l'état des éléments de fixation du porte-vélos, en particulier après avoir parcouru les premiers Km suivant l'installation et, à chaque occasion, avant et après les plus longs trajets pour éviter tout dommage au Carry-Bike et/ou au véhicule. Vérifier régulièrement les éléments en caoutchouc sous les étriers supérieurs et/ou inférieurs ainsi que les sangles; s'ils devaient s'avérer poreux ou abîmés, remplacez-les immédiatement.

Conseil pour le transport: avant de charger le vélo électrique sur le porte-vélos, il est recommandé de retirer la batterie.

ES

Fiamma declina cualquier responsabilidad por daños materiales o lesiones personales imputables a un uso o montaje inadecuado del producto; aconsejamos guardar el manual de instrucciones dentro del vehículo.

El montaje del producto debe realizarse conforme a las instrucciones de montaje: el producto no debe ser cambiado de ninguna manera.

Tener en cuenta la presencia del Carry-Bike, poniendo cuidado durante la conducción y especialmente mientras se realizan maniobras de marchas atrás, sobretodo si el vehículo está equipado con sensores de aparcamiento.

Es importante verificar que en caso de uso con remolque, permanezca accesible el enganchador de vagones y que sea garantizadas movilidad angular del remolque (medidas del volumen din 74058).

Controlar periódicamente el estado de fijación del Carry-Bike sobretodo después de los primeros Kms y cada vez antes y después de los viajes más largos, asegurándose que los estribos no se hayan desplazados, para evitar daños del Carry-Bike y/o del vehículo, revisar regularmente las partes de goma debajo de los soportes superiores y / o inferiores, así como las correas; sustituir las inmediatamente si están porosas o desgastadas.

Se recomienda sacar las baterías de las bicicletas, antes de cargarlas en el carry-bike durante el viaje.



NO

Fiamma fraskriver seg ethvert ansvar for eventuelle personskader og skader på gjenstander som skyldes feilaktig montering eller bruk av produktet. Vi anbefaler at du oppbevarer instruksjonene for sykkelstativet inne i kjøretøyet.

Montering av produktet må utføres i tråd med monteringsinstruksjonene. Det må ikke under noen omstendigheter foretas endringer på produktet.

Vær oppmerksom på Carry-Bike. Pass på under vanlig kjøring og særlig under rygging, spesielt hvis kjøretøyet er utstyrt med parkeringssensorer.

Kontroller, i tilfelle av bruk med henger, at festekrokene er tilgjengelig og at vinkelbevegelsen til hengeren er garantert (volummåling DIN 74058).

Kontroller jevnlig festene til sykkelstativet, særlig etter at du har kjørt de første kilometerne etter montering og hver gang før og etter lengre reiser, for å unngå skader på Carry-Bike og/eller kjøretøyet. Kontroller regelmessig gummidelene under de øvre og/eller nedre stengene, og kontroller reimene. Hvis disse skulle være porøse eller slitte må du umiddelbart skifte dem ut. Vi anbefaler at du fjerner batteriene fra syklene før du laster dem på sykkelstativet for kjøring.

FI

Fiamma ei vastaa mahdollisista asennuksen tai tuotteen virheellisen käytön johdosta henkilölle tai omaisuudelle aiheutuneista vahingoista. On suositeltavaa säilyttää pyörätelineen ohjeet ajoneuvossa.

Tuote on asennettava asennusohjeiden mukaisesti: tuotetta ei saa millään tavoin muuttaa.

Huomioi Carry-Biken paikallaolo ja ole varovainen ajon ja ennen kaikkea peruuttamisen aikana, erityisesti jos ajoneuvossa on pysäköintianturit.

Jos käytät perävaunua varmista, että hinauskoukku on saavutettavissa ja että perävaunun kulmaliikkuvuus taataan (mitta DIN 74058).

Tarkasta säännöllisesti pyörätelineen kiinnitys, erityisesti ajettuasi ensimmäiset kilometrit asentamisen jälkeen ja aina ennen pitkiä matkoja sekä niiden jälkeen, jotta vältät Carry-Biken ja/tai ajoneuvon vahingoittumisen. Tarkasta säännöllisesti kumiosat ylä- ja/tai alatukien alla sekä hihnat. Jos ne ovat huokoiset tai kuluneet, vaihda ne heti.

On suositeltavaa poistaa polkupyöristä akut ennen niiden kuormaamista telineeseen matkan aikana.

PT

Fiamma declina quaisquer responsabilidades para eventuais lesões pessoais e danos aos objetos devidos à montagem ou ao uso errado do produto; sugerimos que guarde as instruções do porta-bicicleta no interior do veículo.

A montagem do produto deve ser executada respeitando as instruções de montagem: o produto não deve ser modificado de modo algum.

Ter sempre em conta a presença do Carry-Bike, prestando atenção durante o andamento e sobretudo durante as manobras de marcha-atrás, em especial se o veículo for dotado de sensores de estacionamento.

Verificar que, em caso de utilização com atrelado, fique acessível o gancho de reboque e que esteja garantida a mobilidade angular do atrelado (medição do volume DIN 74058).

Controlar periodicamente o estado de fixação do porta-bicicletas sobretudo depois de ter percorrido os primeiros Km após a montagem e sempre antes e depois das viagens mais compridas, para evitar danos no Carry-Bike e/ou no veículo, verificar regularmente quer as partes de borracha por baixo dos suportes superiores e/ou inferiores, quer as correias; se estiverem porosas ou gastas, substituí-las imediatamente.

E aconselhável remover as baterias das bicicletas, antes de as carregar no porta-bicicletas durante a viagem.

BIKE-BLOCK PRO S

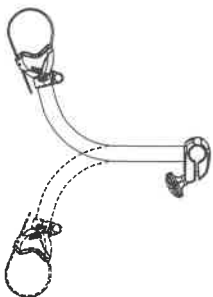

BIKE-BLOCK PRO S D

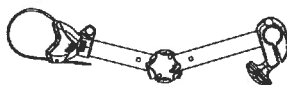

BIKE FRAME ADAPTER

Item No. 06602-01-

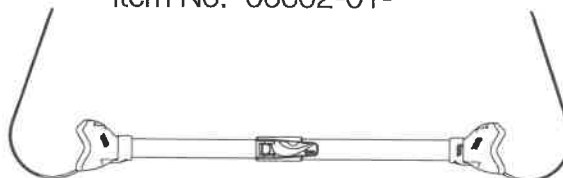

CABLE-LOCK

Item No. 98656-338





- EN Warranty Fiamma**
In case of defects with regards to materials and manufacturing, the customer is entitled to the warranty in accordance with local laws and regulations of the country in which the product was purchased.
- DE Garantie Fiamma**
Im Falle einer Nonkonformität der Ware, kann der Verbraucher unter den erforderlichen Voraussetzungen gegenüber dem Verkäufer von dem Garantieanspruch zu den festgelegten Bedingungen gemäss den lokalen Rechtsvorschriften Gebrauch machen.
- FR Garantie Fiamma**
En cas d'un défaut de conformité du produit, le consommateur pourra faire valoir ses droits de recours en garantie selon les modalités prévues par les dispositions légales locales, pour autant que les conditions de recours soient satisfaites.
- ES Garantía Fiamma**
En caso de fallos o defectos de material y de fabricación, el cliente puede hacer valer la garantía de acuerdo con las leyes y reglamentaciones del país en el que el producto haya sido comprado.
- IT Garanzia Fiamma**
In caso di difetto di conformità dei beni, il consumatore potrà far valere nei confronti del venditore la garanzia secondo le modalità previste dalle disposizioni di legge locali, ove ne ricorrano i presupposti.
- NL Fiamma garantie**
In het geval van gebrek aan overeenstemming van de goederen kan de consument zich beroepen op de wettelijke garantie ten opzichte van de verkoper, zoals vastgelegd in de plaatselijke regelgeving, indien de omstandigheden dit rechtvaardigen.
- SV Fiamma-garanti**
Vid brister på varorna kan konsumenterna åberopa garantin i enlighet med lokal lagstiftning, om omständigheterna berättigar detta.
- DA Garanti Fiamma**
I tilfælde af defekter, hvad angår materialer og fremstilling, er forbrugeren berettiget til forhandlergarantien i henhold til lokale love og bestemmelse i det land, hvori produktet blev fremstillet.
- NO Fiammas garanti**
I tilfelle av defekter ved varene kan forbrukeren fremme sine rettigheter i henhold til garantien overfor forhandleren, i henhold til de reglene som er fastsatt i lokale lover, der forutsetningene for dette er til stede.
- FI Fiamma-takuu**
Jos tuotteiden vaatimustenmukaisuudessa havaitaan puutteita, kuluttaja voi vaatia myyjältä takuun mukaisia oikeuksia paikallisen lainsäädännön puitteissa, mikäli vaatimus on perusteltu.
- PT Garantia Fiamma**
Em caso de defeito de conformidade dos bens, o consumidor poderá fazer valer, em relação ao vendedor, a garantia segundo as modalidades previstas pelas disposições de lei locais, se existirem os pressupostos para tal.



fiamma.com

Fiamma S.p.A. - Italy
Via San Rocco, 56
21010 Cardano al Campo (VA)

MO_IS_98690M035_revD

All rights reserved.
Fiamma S.p.A.
reserves the right to modify at any time,
without notice, prices, materials,
specifications and models or to cease
production of any model.

